

For further assistance, please call our Customer Support team on 0845 641 3010 who will be happy to help.

Gas Service Entry Types

Semi-concealed Meter Box

The semi-concealed meter box can provide an unobtrusive installation partly buried at the foot of the outer wall of the property.

www.fulcrum.co.uk

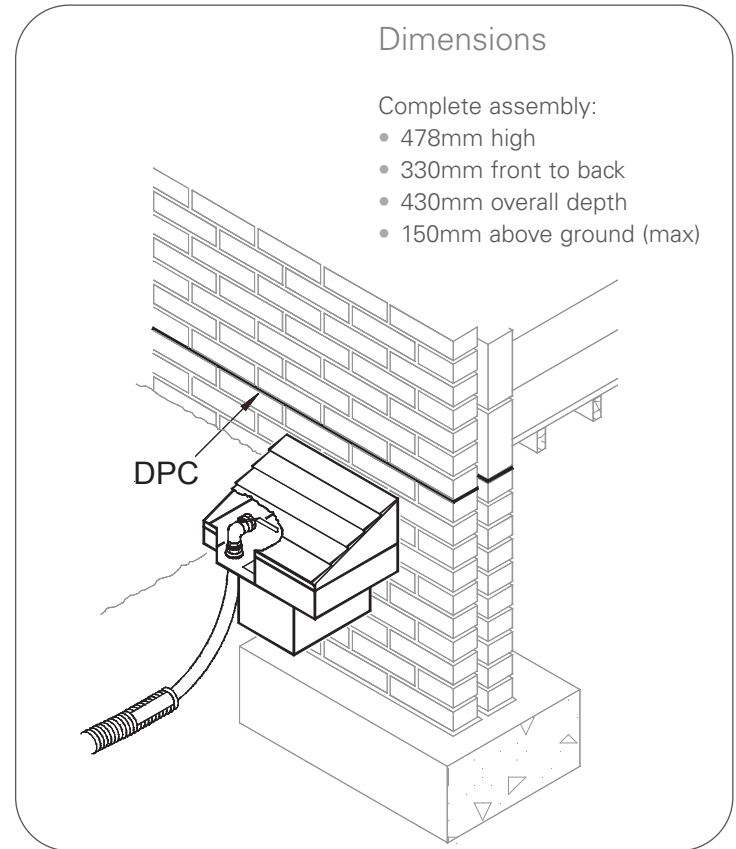

Description

The semi-concealed box can provide an unobtrusive installation, partly buried at the foot of the outer wall of the property, projecting as little as 100mm above the ground (depending on the type of semi-concealed meter box specified by the adopting Gas Transporter) and ideally two brick courses below the damp proof course. Fulcrum will normally be responsible for the provision and installation of semi-concealed meter boxes.

Preparation Required Before Gas Service Pipe Installation

- The meter box must be inspected for signs of damage when delivery is made to site. A damaged box must never be installed.
- It must be situated as per the Fulcrum design and where it will not cause an obstruction or be exposed to damage from vehicles etc.
- An excavation of 500mm wide by 750 long by 500mm deep will normally be adequate (depending upon the semi-concealed meter box manufacturer and type) to position the box, to receive the service pipe.
- The installation (outlet) pipe must be fixed to the outlet adapter located at the right hand side of the box (when viewed from the front).

